

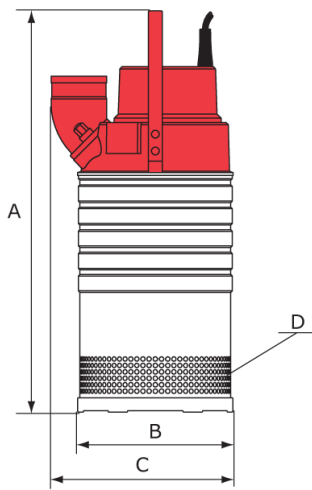

Master SH

Electrical submersible drainage pump



50 Hz	SH
Discharge connection	3"
Rated power P_2 [kW]	8,8
Max. power consumption P_1 [kW]	10,2
Shaft speed [r.p.m.]	2835
Rated current at 230V	29 A
Rated current at 400V	16 A
Rated current at 500V	13 A
Dimensions A / B / C	720 / 286 / 330 mm
Weight	60 kg

Other voltages on request

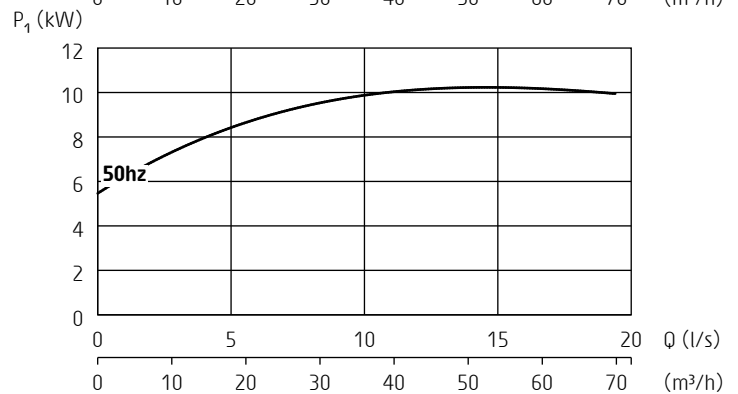
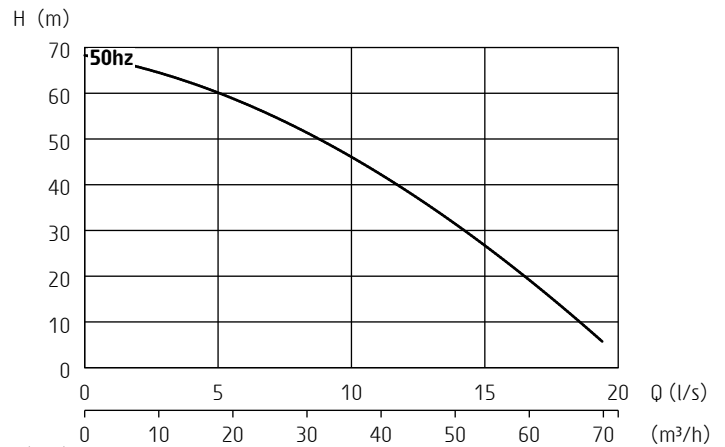

ISO 9906/A

Classification

Electrical submersible drainage pump
Protection class: IP 68

Electrical motor

Squirrel cage induction motor, insulation class: H (IEC 85)

Motor protection

Phase sequence control, phase failure guard, temperature guard with thermal contacts in the stator opening temperature 140°C (284°F) (= SMART system), air valve

Cable - SubCab

230V: 4G6mm², 20 m (66 ft) / 10AWG/4, 53 ft
380-575V: 4G2.5mm², 20 m (66 ft) / 12AWG/4, 53 ft

Limitations

Max. submersion depth: 20 m (66 ft)
Max. liquid temperature: 40 °C (104 °F)
Allowed pH range: 5 - 8
Maximum liquid density: 1100 kg/m³ (68 lbs/ft³)

Shaft seals

Double mechanical seal running in an oil compartment
Material lower seal: *silicon carbide - silicon carbide*
Material upper seal: *silicon carbide - silicon carbide*

Bearings

Ball bearings with C3 clearance

Discharge connection

3" hose, ISO-G or NPT

Materials

Casted parts: *Aluminium*
Outer casing: *Stainless steel*
Motor shaft: *Stainless steel*
Impeller: *Hard-Iron™*
Suction cover: *Hard-Iron™*
Diffusers: *Nitrile rubber*
Screws and nuts: *Stainless steel*
O-rings: *Nitrile rubber*

Accessories

Tandem connection
Zinc anodes

Specifications can be changed without notice